



**VOLKSWAGEN TRANSPORTER  
CREW CAB**



## COMFORT • DESIGN • FUNCTIONALITY

Expand the usability of the Volkswagen Transporter with the Crew Cab. Add three additional seats that integrate seamlessly with the rest of the vehicle. The ergonomic and spacious design ensures a comfortable and safe journey. The cabin features a premium finish that provides exceptional sound insulation while meeting the highest quality and safety standards.

The Volkswagen Transporter with Crew Cab is the perfect balance between functionality and style, suitable for daily and professional use.

# CREW CAB CONFIGURATIONS\*

Check which Crew Cab is suitable for your vehicle

## BASE VEHICLE IS EQUIPPED WITH

	TRIMLEVELS		
	BASE	LUXE	EXCLUSIVE
<b>SLIDING DOOR</b>	L2	L2	L2
Sliding door right	●	●	●
Sliding door left (right hand drive only)	●	—	—
Sliding door right and left	●	●	●
Electric sliding door right	○	○	○
Electric sliding door left (right hand drive only)	○	—	—
Electric sliding door right and left	○	○	○
<b>WINDOWS</b>			
Factory-fitted windows second seating row	●	●	●
No factory-fitted windows second seating row, retrofitted	○	○	○
<b>FRONT CABIN</b>			
Front passenger seat	●	●	●
Front passenger bench	●	●	●
<b>ROOF HEIGHT</b>			
H1	●	●	●
H2	—	—	—
<b>UPHOLSTERY FABRIC</b>			
Checkered fabric (N2Q)	●	●	—
Striped fabric (N2S)	●	●	●
Fabric "Life" (N2R)	—	—	●
Eco-leather "Style" (N2H)	—	—	●

- \* Suitable for all drivetrains
- Standard
- Available with additional charge
- Not available

Configure online: [customerportal.snoeks.com](https://customerportal.snoeks.com)





## MAXIMUM CONVENIENCE

The practical design of the Crew Cab maximizes space and is equipped with the latest technology. Passengers enjoy spacious seating and a relaxing journey. Stay connected on the road with the integrated USB A/C ports in the armrests. Keep the vehicle organized using the storage compartments under the bench and in the side panels.

Choose the Crew Cab, add additional seats to your vehicle and combine the daily transportation of cargo and passengers.



### 01 ISOFIX AND TOP TETHER

Mount car seats easy and safe using the integrated ISOFIX en Top Tether functionalities on the outer seats.



02

### 02 SEAT BELT REMINDER SYSTEM

All seats are equipped with a seat belt reminder system. This feature ensures maximum safety by reminding passengers to wear a seat belt while driving.

### 03 COMPAX® PARTITION WALL WITH EXTENDED CARGO SPACE

The premium lightweight and sustainable partition wall is made of PET-fiber. The black-grey blended fabric adds a luxurious look to the interior. The thermal-isolation and sound-dampening partition wall maintains the ideal temperature in the cabin. The loading space underneath the bench can transport materials up to 2.37 meters in length.



03



### **01 LUXURIOUS SIDE PANEL LINING**

The high-quality sidewall trim gives the cab a professional look. Depending on the Crew Cab variant you choose, the side wall is equipped with a storage compartment and cup holder.

### **02 LED SPOTLIGHTS**

The Luxe and Exclusive Crew Cab variants feature three integrated LED spotlights in the rooflining ensuring a brightly lit cabin.

### **03 SPEAKER SYSTEM**

For a comprehensive audio experience, the Exclusive Crew Cab is included with an integrated speaker system in the bottom side of the bench.

# SPECIFICATIONS AND OPTIONS

Choose the ideal Crew Cab trim level

	BASE	LUXE	EXCLUSIVE
	L2H1	L2H1	L2H1
<b>SEPARATION WALL AND SEATING</b>			
Compax separation wall	•	•	•
Three-Seater bench covered with fabric as front seats	•	•	—
Three individual seats, two of which are adjustable, including two armrests and upholstery matching the front seats	—	—	•
Two folding seat cushions with storage compartments and covered with fabric as front seats (sliding functionality of seats not possible)	—	—	o
Armrests (two) with integrated USB-A/C charger	—	—	•
ISOFIX and Top Tether on two outer seats	•	•	•
Three-point safety belt	•	•	•
Headrest (three) in height adjustable	•	•	•
Storage in bench front	•	•	•
Foldable backrest including cupholders and storage space	—	—	•
Speaker system integrated in bottom side of the bench	—	—	•
Ambient lighting in bench front	—	•	•
<b>FLOOR</b>			
Lightweight EPP floor in front of second seating row	•	•	•
Removable carpet on the floor in front of second seating row	—	•	•
Step-in cover in front of second seating row	•	•	•
<b>SIDEWALL FINISHING</b>			
Bottom of fixed wall and sliding door finished with lower panel	•	—	—
Basic vehicle equipped with right sliding door: fixed wall finished with ABS-plastic, including inlays, storage compartments and cupholder	—	•	•
Basic vehicle equipped with sliding door(s): lower and upper cover finished with ABS-plastic, including inlay and storage compartment	—	•	•
Roll-up sun blinds left and right	—	—	•
<b>ROOFLINING</b>			
Tooled rooflining, covered with fabric as front headlining	•	•	•
LED-spots in headlining with on/off switch (three)	—	•	•

- Standard
- o Available with additional charge
- Niet beschikbaar

Configure online: [customerportal.snoeks.com](https://customerportal.snoeks.com)



# DIMENSIONS

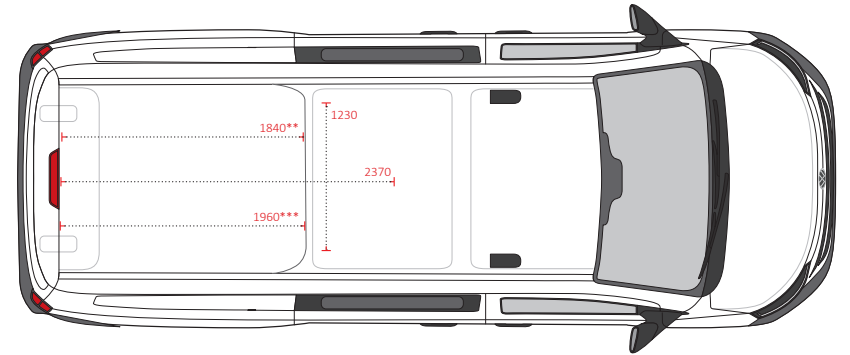
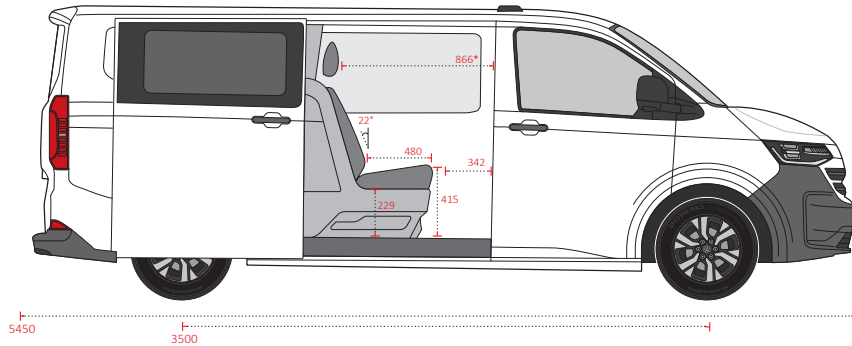

	<b>L2H1</b>
	cm
<b>EXTERIOR</b>	
Overall vehicle length	5450
Wheelbase	3500
<b>CREW CAB</b>	
Leg space to front cabin	342
Afstand headrest second seating row to front cabin*	866
Seating length	480
Seating height	415
Backrest inclination	22°
<b>LOADING COMPARTMENT</b>	
Lenght loading compartment**	1840
Lengte loading compartment***	1960
Floor width loading compartment under the bench	1230
Floor length loading compartment	2370
Height loading compartment under the bench	229

\* Measured from center of driver seat in rear position

\*\* Measured at 1300 mm height

\*\*\* Measured at 200 mm height

Total conversion weight: 105 kg

Conversion is available for vehicles from 2800 kg GVW



 [info@snoeks.com](mailto:info@snoeks.com)

 [www.snoeks.com](http://www.snoeks.com)

 +31 (0) 252 629 529

 Kunaweg 3, 2153 NC, Nieuw-Vennep, The Netherlands

Specifications, features, versions and prices are subject to change. Snoeks Automotive reserves the right to make interim changes to their products and the content of this publication. Consult the current price lists, product information and sales conditions on [customerportal.snoeks.com](http://customerportal.snoeks.com).