



FIAT DUCATO
Crew Cab

CREW CAB

Fiat Ducato

The perfect solution

A Fiat Ducato that is equipped with a Crew Cab from Snoeks is the ideal solution for transporting people and cargo safely, comfortably and efficiently.

Merged Perfection

The Snoeks Crew Cab series is specifically designed for the Fiat Ducato and therefore fits seamlessly into the vehicle and matches the design of the front cab. That is what we like to call, "Merged Perfection".

For every type of Ducato

No matter what type of Ducato you have, we have a suitable Crew Cab in our program. In addition, we offer three different trim levels, with which you can choose the desired equipment level.



**MERGED
PERFECTION**

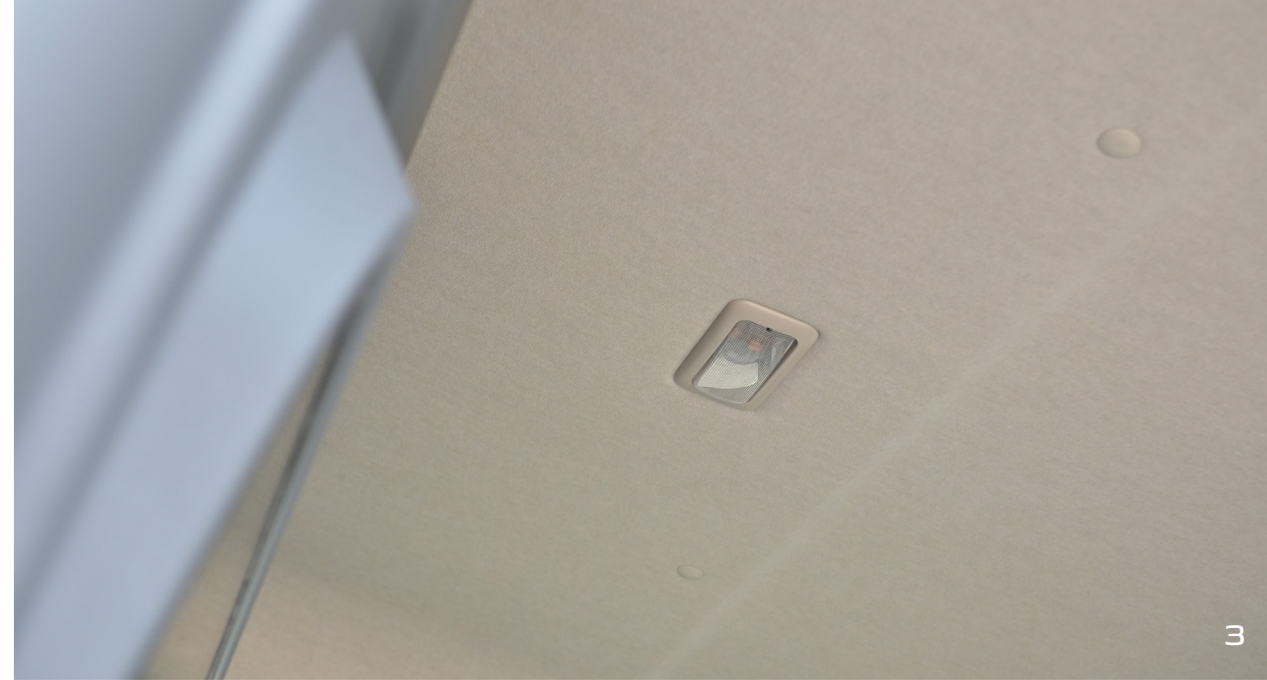

UNIQUE BENEFITS

Fiat Ducato Crew Cab

1. Maximum comfort

A Ducato with a Crew Cab offers up to three additional seats with maximum comfort for your passengers. Optional you can choose a four seater bench.

2. Maximum load area

Thanks to the clever design of the Crew Cab, the loss of cargo space is minimal.

3. Unique character

There is a choice between three Trim levels: Base, Comfort and Luxury. From the Comfortline you receive lighting in the headliner.

4. Optimal safety

The Crew Cab meets the European safety requirements. All seats are equipped with 3-point safety belts and functional headrests.

5. Practical interior

Your passengers can easily store small items in the handy storage compartments in the bench and in the sidewall.

6. Your business card

In every detail, the Ducato Crew Cab looks stylish and is completely in line with the design of your Fiat Ducato.

7. Long objects

The practical loading space under the bench allows to transport long items.



Specifications above can be different per trim level, view an overview further in this brochure.

TRIMLEVELS

Fiat Ducato Crew Cab



Base

- A comfortable three-seater bench
- Adjustable and tilting headrests
- 3-Point inertia-reel safety belt on all seating positions
- Storage pocket in bench cover
- Loading space under the bulkhead
- Wear-resistant floor and step-in cover



Comfort

extra compared to Base:

- Luxury sidewall finishing including a cupholder
- Headlining covered with fabric incl. lighting



Luxury

extra compared to Comfort:

- A comfortable three-seater bench with two armrests
- Easy entry with step-in handle
- Luxury sidewall finishing including storage pockets and a cupholder

Options

- A comfortable four-seater bench
- Privacy glass

BASE VEHICLE & POSSIBILITIES

	L1			L2			L3			L4		
	BASE	COMFORT	LUXURY	BASE	COMFORT	LUXURY	BASE	COMFORT	LUXURY	BASE	COMFORT	LUXURY
SLIDING DOOR												
Sliding door right	o	o	o	o	o	o	o	o	o	o	o	o
Sliding door left	o	x	x	o	o	o	o	o	o	o	o	o
Sliding door right and left	Δ	x	x	Δ	Δ	Δ	Δ	Δ	Δ	Δ	Δ	Δ
WINDOWS												
factory fitted window right	o	o	o	o	o	o	o	o	o	o	o	o
Factory fitted window left	o	x	x	o	x	x	o	x	x	o	x	x
No factory fitted windows	Δ	Δ	Δ	Δ	Δ	Δ	Δ	Δ	Δ	Δ	Δ	Δ
OTHER												
Co-driver's seat	o	o	o	o	o	o	o	o	o	o	o	o
Co-driver's bench	o	o	o	o	o	o	o	o	o	o	o	o
ROOF HEIGHT												
H1	o	o	o	o	o	o	x	x	x	x	x	x
H2	x	x	x	o	o	o	o	o	o	o	o	o
H3	x	x	x	x	x	x	x	o	o	x	o	o

o Available
 Δ Available for an additional charge
 x Not available

FABRIC



Crepe Black Fabric
173



Crepe Black Fabric
076

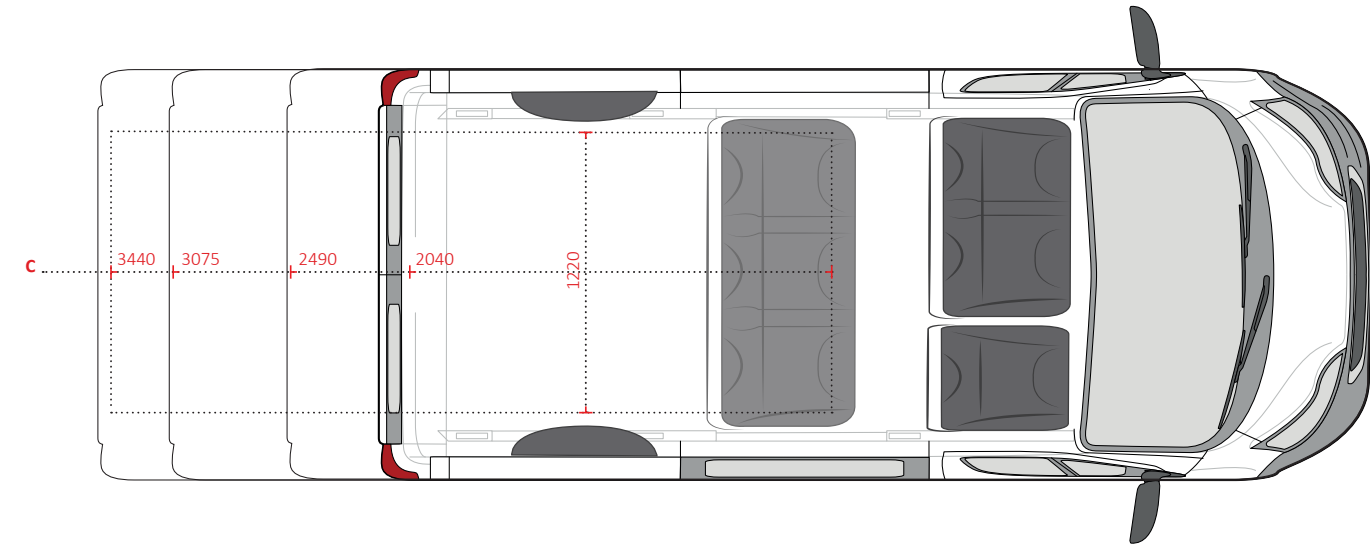
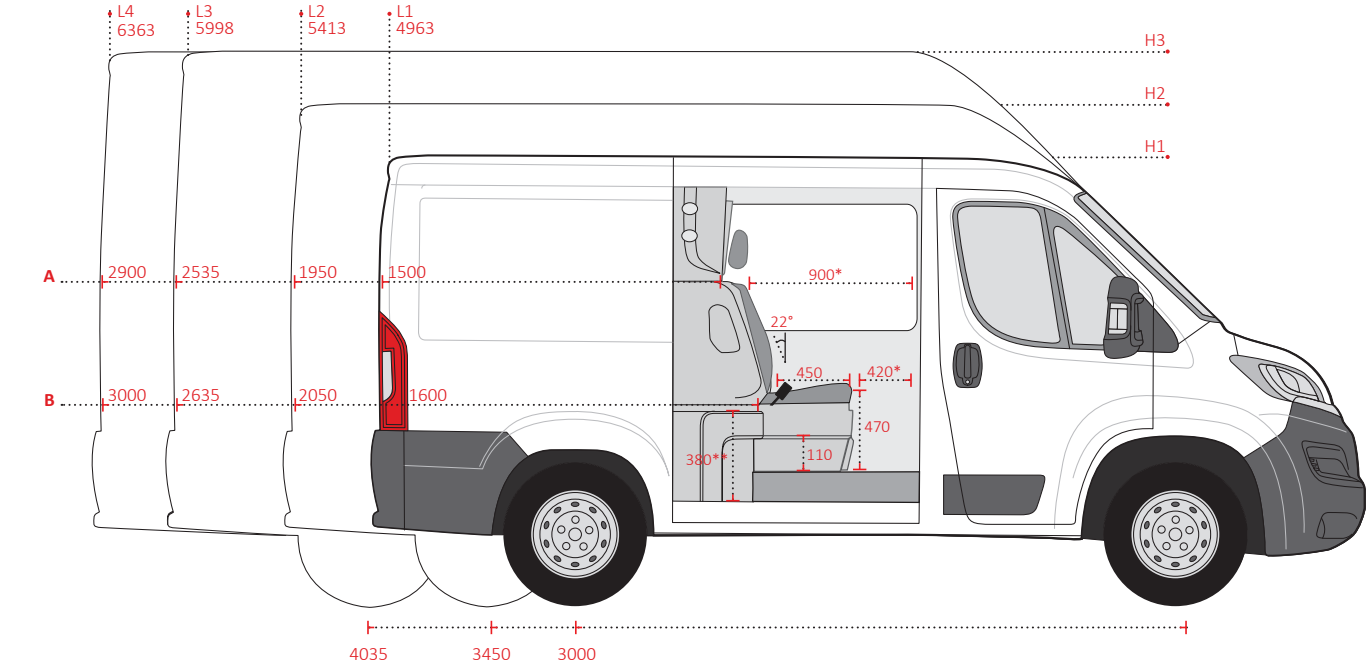

* Measured in relation to fixed co-driver's bench

Note:
 Crew cab conversion weight is 105 kg.

LOAD AREA	A	B	C
L1	1500	1600	2040
L2	1950	2050	2490
L3	2535	2635	3075
L4	2900	3000	3440

 info@snoeks.com

 www.snoeks.com

 +31 (0) 252 629 529

 Kunaweg 3, 2153 NC, Nieuw-Vennep, The Netherlands

© All rights reserved. Snoeks Automotive reserves the right to change or improve its products and to make changes in the content of this brochure without obligation to notify any person or organization of such changes or improvements.
The images shown may differ from the standard trimlevel.



FIAT DUCATO

Crew Cab - Pricelist

BASE VEHICLE & POSSIBILITIES

	L1			L2			L3			L4		
	BASE	COMFORT	LUXURY	BASE	COMFORT	LUXURY	BASE	COMFORT	LUXURY	BASE	COMFORT	LUXURY
SLIDING DOOR												
Sliding door right	o	o	o	o	o	o	o	o	o	o	o	o
Sliding door left	o	x	x	o	o	o	o	o	o	o	o	o
Sliding door right and left	Δ	x	x	Δ	Δ	Δ	Δ	Δ	Δ	Δ	Δ	Δ
WINDOWS												
factory fitted window right	o	o	o	o	o	o	o	o	o	o	o	o
Factory fitted window left	o	x	x	o	x	x	o	x	x	o	x	x
No factory fitted windows	Δ	Δ	Δ	Δ	Δ	Δ	Δ	Δ	Δ	Δ	Δ	Δ
OTHER												
Co-driver's seat	o	o	o	o	o	o	o	o	o	o	o	o
Co-driver's bench	o	o	o	o	o	o	o	o	o	o	o	o
ROOF HEIGHT												
H1	o	o	o	o	o	o	x	x	x	x	x	x
H2	x	x	x	o	o	o	o	o	o	o	o	o
H3	x	x	x	x	x	x	x	o	o	x	o	o

o Available
 Δ Available for an additional charge
 x Not available

FABRIC



Crepe Black Fabric
173



Crepe Black Fabric
076

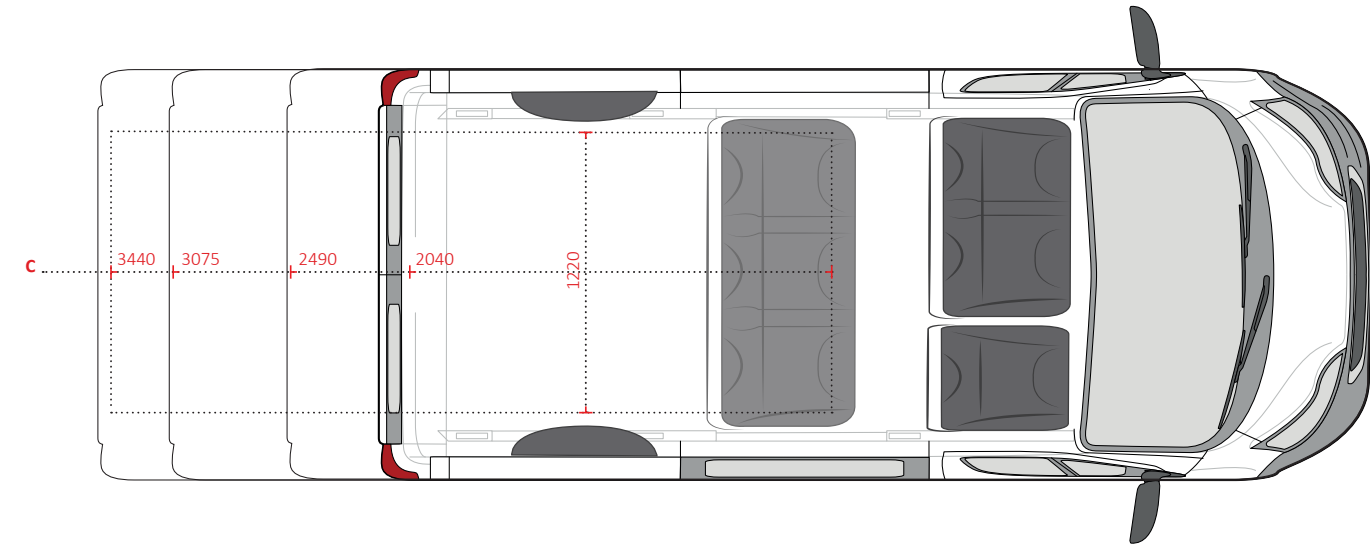
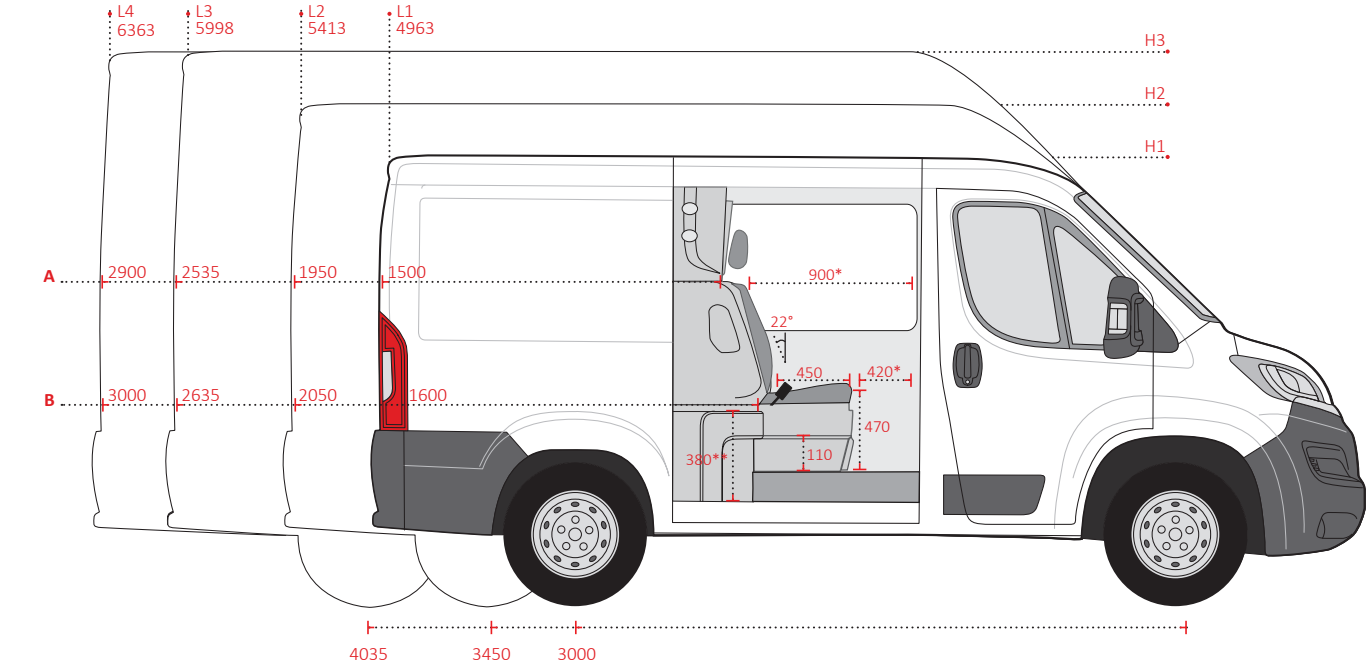

* Measured in relation to fixed co-driver's bench

Note:
 Crew cab conversion weight is 105 kg.

LOAD AREA	A	B	C
L1	1500	1600	2040
L2	1950	2050	2490
L3	2535	2635	3075
L4	2900	3000	3440

STANDARD EQUIPMENT & OPTIONS

Recommended prices - Fiat Ducato

	BASE				COMFORT				LUXE			
	L1	L2	L3	L4	L1	L2	L3	L4	L1	L2	L3	L4
BASE VEHICLE												
Gross sales price H1	3405	3405	-	-	4450	4450	-	-	4975	4975	-	-
Gross sales price H2	-	3800	3800	3800	-	4450	4450	4450	-	5500	5500	5500
Gross sales price H3	-	-	-	-	-	-	4840	4840	-	-	5885	5885
OBLIGATED EXTRA PRICES												
Seat Belt Reminder system	220	220	220	220	220	220	220	220	220	220	220	220
Base vehicle equipped with sliding door left and right	75	75	75	75	-	75	75	75	-	75	75	75
Disassembly original bulkhead, including assembly B-pillar covers	240	240	240	240	240	240	240	240	240	240	240	240
Adjustments to factory fitted wooden floor	50	50	50	50	50	50	50	50	50	50	50	50
Adjustments to factory fitted sidewall finishing	75	75	75	75	75	75	75	75	75	75	75	75
WINDOWS												
Window left or right (price per piece)	265	265	265	265	265	265	265	265	265	265	265	265
Windows left and right, privacy glass	635	635	635	635	635	635	635	635	635	635	635	635
Ceramic windows *	465	465	465	465	465	465	465	465	465	465	465	465
ABS PARTITION WALL WITH INTEGRATED SAFETY WINDOW												
Bench cover with storage pocket, additional load space under the bulkhead	■	■	■	■	■	■	■	■	■	■	■	■
SEATING												
3-Seater contoured bench	■	■	■	■	■	■	■	■	-	-	-	-
3-Seater contoured bench with 2 armrests in between	-	-	-	-	-	-	-	-	■	■	■	■
4-Seater contoured bench	210	210	210	210	210	210	210	210	-	-	-	-
Adjustable head restraints on all seating positions, as front seats	■	■	■	■	■	■	■	■	■	■	■	■
3-Point inertia-reel safety belt on all seating positions	■	■	■	■	■	■	■	■	■	■	■	■
FLOOR												
Floor heightening	■	■	■	■	■	■	■	■	■	■	■	■
Luxury step-in cover plastic, black	■	■	■	■	■	■	■	■	■	■	■	■
Floor before 2nd seat row, covered with fixed rubber mat	■	■	■	■	■	■	■	■	-	-	-	-
Floor before 2nd seat row, covered with fixed carpet mat	-	-	-	-	-	-	-	-	■	■	■	■

Gross prices exclusive VAT

	BASE				COMFORT				LUXURY			
	L1	L2	L3	L4	L1	L2	L3	L4	L1	L2	L3	L4
SIDE-WALL FINISHING												
Off-side finished with factory fitted lower cover	■	■	■	■	-	-	-	-	-	-	-	-
Sliding door(s) finished with factory fitted lower cover	■	■	■	■	■	■	■	■	■	■	■	■
Off-side finished with lower and upper cover in tooled ABS-plastic, including cupholder	-	-	-	-	■	■	■	■	-	-	-	-
Off-side finished with lower and upper cover in tooled ABS-plastic, including cupholder and storage pocket	-	-	-	-	-	-	-	-	■	■	■	■
Storage pockets integrated in lower off-side cover	-	-	-	-	-	-	-	-	■	■	■	■
Sliding door(s) finished with lower and upper cover in tooled ABS-plastic	-	-	-	-	-	-	-	-	-	■	■	■
Grip handle(s) B-pillar, sliding door entrance	-	-	-	-	-	-	-	-	-	■	■	■
HEADLINING												
Tooled ABS-plastic headlining	-	-	-	-	■	■	■	■	■	■	■	■
H2: Partition wall extension part including front headlining	-	■	■	■	-	-	-	-	-	-	-	-
H2: Partition wall extension part including ABS-plastic finishing windows and front headlining	-	-	-	-	-	■	■	■	-	■	■	■
H3: In addition to H2 ceiling with plywood top	-	-	-	-	-	-	■	■	-	-	■	■
APPROVAL												
Contribution homologation costs	150	150	150	150	150	150	150	150	150	150	150	150

- Standard
- Not available

Gross prices exclusive VAT

Explanation features and options:

Prices only apply in combination with a double cabin kit. Pricing ex-works, a surcharge for single packaging and transport applies.

- * Ceramic windows can only be ordered in combination with a Crew Cab.

STANDARD EQUIPMENT & OPTIONS

Kit prices - Fiat Ducato

	BASE				COMFORT				LUXE			
	L1	L2	L3	L4	L1	L2	L3	L4	L1	L2	L3	L4
BASE VEHICLE												
Gross sales price H1	2470	2470	-	-	3045	3045	-	-	3785	3785	-	-
Gross sales price H2	-	2775	2775	2775	-	3345	3345	3345	-	4090	4090	4090
Gross sales price H3	-	-	-	-	-	-	3735	3735	-	-	4475	4475
OBLIGATED EXTRA PRICES												
Seat Belt Reminder system	145	145	145	145	145	145	145	145	145	145	145	145
Base vehicle equipped with sliding door left and right	70	70	70	70	-	70	70	70	-	70	70	70
Disassembly original bulkhead, including assembly B-pillar covers	210	210	210	210	210	210	210	210	210	210	210	210
WINDOWS												
Window left or right (price per piece)	125	125	125	125	125	125	125	125	125	125	125	125
Windows left and right, privacy glass	365	365	365	365	365	365	365	365	365	365	365	365
Ceramic windows *	360	360	360	360	360	360	360	360	360	360	360	360
ABS PARTITION WALL WITH INTEGRATED SAFETY WINDOW												
Bench cover with storage pocket, additional load space under the bulkhead	■	■	■	■	■	■	■	■	■	■	■	■
SEATING												
3-Seater contoured bench	■	■	■	■	■	■	■	■	-	-	-	-
3-Seater contoured bench with 2 armrests in between	-	-	-	-	-	-	-	-	■	■	■	■
4-Seater contoured bench	125	125	125	125	125	125	125	125	-	-	-	-
Adjustable head restraints on all seating positions, as front seats	■	■	■	■	■	■	■	■	■	■	■	■
3-Point inertia-reel safety belt on all seating positions	■	■	■	■	■	■	■	■	■	■	■	■
FLOOR												
Floor heightening	■	■	■	■	■	■	■	■	■	■	■	■
Luxury step-in cover plastic, black	■	■	■	■	■	■	■	■	■	■	■	■
Floor before 2nd seat row, covered with fixed rubber mat	■	■	■	■	■	■	■	■	-	-	-	-
Floor before 2nd seat row, covered with fixed carpet mat	-	-	-	-	-	-	-	-	■	■	■	■

Gross prices exclusive VAT

	BASE				COMFORT				LUXURY			
	L1	L2	L3	L4	L1	L2	L3	L4	L1	L2	L3	L4
SIDE-WALL FINISHING												
Off-side finished with factory fitted lower cover	■	■	■	■	-	-	-	-	-	-	-	-
Sliding door(s) finished with factory fitted lower cover	■	■	■	■	■	■	■	■	-	-	-	-
Off-side finished with lower and upper cover in tooled ABS-plastic, including cupholder	-	-	-	-	■	■	■	■	-	-	-	-
Off-side finished with lower and upper cover in tooled ABS-plastic, including cupholder and storage pocket	-	-	-	-	-	-	-	-	■	■	■	■
Storage pockets integrated in lower off-side cover	-	-	-	-	-	-	-	-	■	■	■	■
Sliding door(s) finished with lower and upper cover in tooled ABS-plastic	-	-	-	-	-	-	-	-	-	■	■	■
Grip handle(s) B-pillar, sliding door entrance	-	-	-	-	-	-	-	-	-	■	■	■
HEADLINING												
Tooled ABS-plastic headlining	-	-	-	-	■	■	■	■	■	■	■	■
H2: Partition wall extension part including front headlining	-	■	■	■	-	-	-	-	-	-	-	-
H2: Partition wall extension part including ABS-plastic finishing windows and front headlining	-	-	-	-	-	■	■	■	-	■	■	■
H3: In addition to H2 ceiling with plywood top	-	-	-	-	-	-	■	■	-	-	■	■
APPROVAL												
Contribution homologation costs	65	65	65	65	65	65	65	65	65	65	65	65

- Standard
- Not available

Gross prices exclusive VAT

Explanation features and options:

Prices only apply in combination with a double cabin kit. Pricing ex-works, a surcharge for single packaging and transport applies.

- * Ceramic windows can only be ordered in combination with a Crew Cab.

 info@snoeks.com

 www.snoeks.com

 +31 (0) 252 629 529

 Kunaweg 3, 2153 NC, Nieuw-Vennep, The Netherlands

© All rights reserved. Snoeks Automotive reserves the right to change or improve its products and to make changes in the content of this brochure without obligation to notify any person or organization of such changes or improvements.
The images shown may differ from the standard trimlevel.

FIAT DUCATO

Possibilities & Restrictions - COC

	L1 engine 2,2		L2 engine 2,2 E-Motor		L3 engine 2,2 E-Motor		L4 engine 2,2 E-Motor	
Type: 2,8								
5 seats	2249							
6 seats	2220							
7 seats	■							
Type: 3,0								
5 seats	2264	2307						
6 seats	2239	2257						
7 seats	2239	2183						
Type: 3,04								
5 seats	2271	2279						
6 seats	2252	2156						
7 seats	2182	2097						
Type: 3,3								
5 seats	2264	2307			2385			
6 seats	2239	2282			2328			
7 seats	2239	2282			2237			
Type 3,34								
5 seats	2271	2314			2397			
6 seats	2271	2314			2257			
7 seats	2275	2318			2175			
Type: 3,5 Light								
5 seats	2278	2321			2399	2438		
6 seats	2253	2296			2374	2413		
7 seats	2253	2296			2374	2413		
Type: 3,5 Heavy								
5 seats	2316	2366	2510*	2444	2613*	2483	2667*	
6 seats	2291	2341	2505*	2419	2608*	2458	2659*	
7 seats	2291	2341	2505*	2419	2579*	2458	■	

Additional information:

The European type approval of Snoeks Automotive is only valid for N1-vehicles.

- e3*2007/46*0044*46 (no type: 3,04 and 3,34 only in ext.45)

- e3*2007/46*0044*39 (Electric Motor)

- **We only cover complete vehicles**

* Some vehicles with very limited options may be possible.

■ Conversion possible

■ Conversion not possible

■ Limited room for options

Check COC point 13 before conversion

1234 Maximum mass in running order before conversion

FIAT DUCATO Multicab MY 2014

Possibilities & Restrictions - COC

	L1 engine		L2 engine		L3 engine		L4 engine	
	2,0/3	3,0*	2,0/3	3,0*	2,0/3	3,0*	2,0/3	3,0*
Type: 2,8								
5 seats	■							
6 seats	■							
7 seats	■							
Type: 3,0								
5 seats	■	■	■	■				
6 seats	■	■	■	■				
7 seats	■	■	■	■				
Type: 3,3								
5 seats	■	■	■	■	■	■		
6 seats	■	■	■	■	■	■		
7 seats	■	■	■	■	■	■		
Type 3,5 Light								
5 seats	■	■	■	■	■	■	■	■
6 seats	■	■	■	■	■	■	■	■
7 seats	■	■	■	■	■	■	■	■
Type: 3,5 Heavy								
5 seats	■	■	■	■	■	■	■	■
6 seats	■	■	■	■	■	■	■	■
7 seats	■	■	■	■	■	■	■	■

Additional information:

The European type approval of Snoeks Automotive is only valid for N1-vehicles.

- Conversion possible
- Conversion not possible
- Limited room for options
- * 2998 cc engine F1CFA401C FPT Industrial (100 kW) CNG EU V1d

Check COC point 13 before conversion

1234 Maximum mass in running order before conversion

FIAT DUCATO FLEXCAB MY 2020

Possibilities & Restrictions - COC ext 36

	L2 engine		L3 engine		L4 engine	
	2,3	2,3	2,3	2,3	2,3	2,3
Type: 3,0						
6 seats	2120					
7 seats	■					
Type: 3,04 Light						
6 seats	2126					
7 seats	■					
Type: 3,3						
6 seats	■	■				
7 seats	■	2195				
Type: 3,34						
6 seats	2243	2240				
7 seats	2140	2140				
Type: 3,5 Light						
6 seats	■	■	■			
7 seats	■	2221	■			
Type: 3,5 Heavy						
6 seats	■	■	■			
7 seats	■	■	■			

Additional information:

The European type approval of Snoeks Automotive is only valid for N1-vehicles.

- Conversion possible
- Conversion not possible
- Limited room for options
- Check COC point 13 mid-engine conversion before conversion

1234 Maximum mass in running order before conversion